

# COOLSET

## *Operating Instructions*

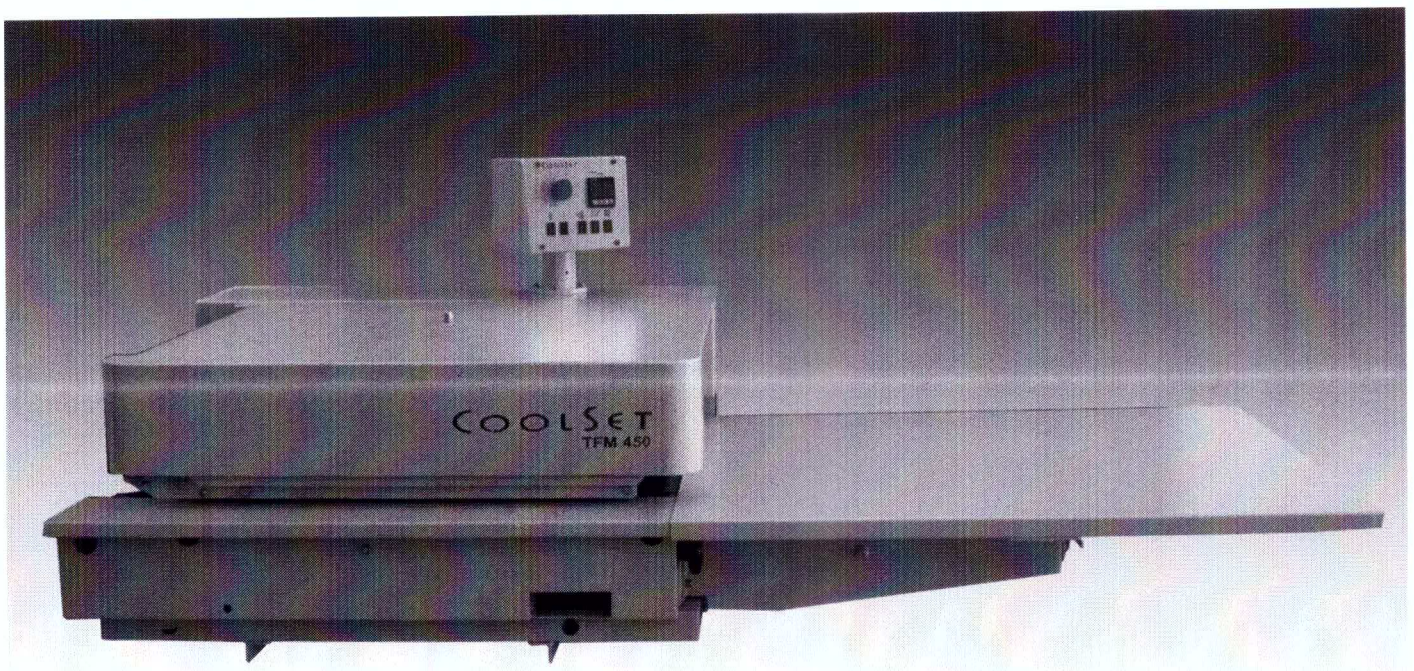

**TFM 450**

***Table Fusing Machine***

# COOLSET

Coolset TFM 450  
Coolset TFM 450 Table Fusing Machine

## Service department

### **VEIT BRISAY Shanghai**

Veit Brisay Press Equip.(Shanghai) Co. Ltd  
Rm 3204, Tower 2, Kerry Everbright City,  
218 West Tian Mu Road, Shanghai,  
China 200070  
Phone: +86 (21) 63530121  
Fax: +86 (21) 63530320  
e-mail: [info@veit.com.cn](mailto:info@veit.com.cn)

### **VEIT BRISAY Hong Kong**

VEIT HONG KONG LIMITED  
ROOM 1115, 11/F, 8 On Ping Street, Sha Tin,  
Hong Kong  
Phone: (852) 2834-9986  
Fax: (852) 2836-0005  
e-mail: [service@veit.com.hk](mailto:service@veit.com.hk)

## Table of Contents

<b>1</b>	<b><i>Product Information</i></b> .....	<b>1</b>
1.1	<i>Description</i> .....	1
1.2	<i>Ordering information and Options Coolset TFM450</i> .....	2
1.3	<i>Technical Data</i> .....	2
<b>2</b>	<b><i>Operating Instructions</i></b> .....	<b>3</b>
2.1	<i>Introduction</i> .....	3
2.2	<i>Warnings and Safety Instructions</i> .....	4
2.3	<i>Installation instructions</i> .....	6
2.3.1	<i>Installation</i> .....	6
2.3.2	<i>Electrical connection</i> .....	6
2.4	<i>Operating</i> .....	7
2.4.1	<i>Commissioning and Start-up</i> .....	7
2.4.2	<i>The holding's adjustments</i> .....	8
2.4.3	<i>Thermostat setting</i> .....	9
2.4.4	<i>Upper belt replacement</i> .....	10
2.4.5	<i>Lower belt replacement</i> .....	13
2.4.6	<i>Breaks and Finishing Service</i> .....	16
2.5	<i>Maintenance and Service</i> .....	17
<b>3</b>	<b><i>Spare Parts List</i></b> .....	<b>18</b>
<b>4</b>	<b><i>Circuit Diagram Electric</i></b> .....	<b>21</b>

COOLSET

Coolset TFM 450  
*Coolset TFM 450 Table Fusing Machine*

# 1 Product Information

## 1.1 Description

This fusing machine is the ideal solution for fusing a wide variety of interlinings and face fabrics.

This is a continuous type machine therefore production is greatly increased. Seamless belts have been used to increase the durability of the belt; the machine will accommodate kinds of fabrics, and produce consistent high quality bonding.

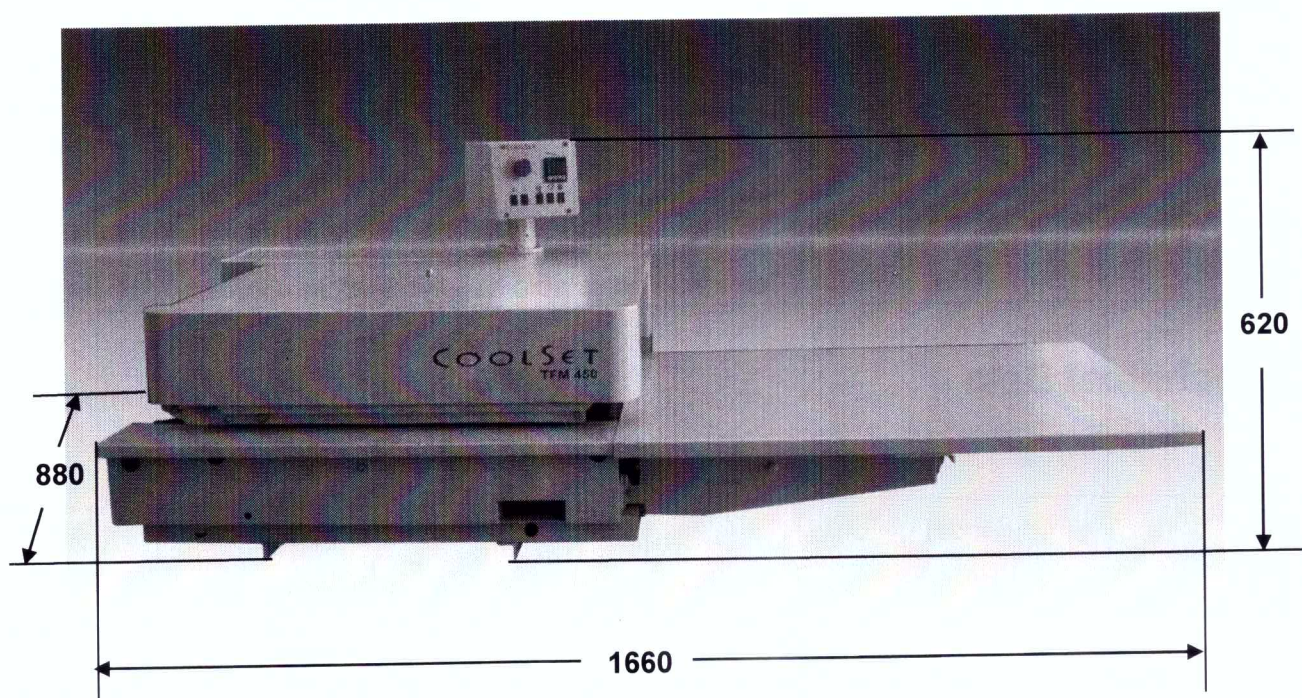

**Field of application:**

- Casual and classic shirts ,trousers and skirts
- Men, women and children shirts, trousers and skirts
- Sports shoes
- Fusing a wide variety of interlinings and face fabrics

## 1.2 Ordering information and Options Coolset TFM450

Art. No.	DESIGNATION
SC010027	STANDARD: Coolset TFM 450 fusing machine
HJ020076 HJ020077 HJ020078 SC040048	OPTIONAL: Unloading slide Rotating strip-off device Cleaning kit Table with adjustable height 65-80cm -Coolset TFM 450

## 1.3 Technical Data

Model		TFM 450
Voltage		1P-220V/50Hz
Power	Heater	4.0Kw
	Motor	40W
Fusing temperature (MAX)		195°C
Pressing pressure (MAX)		1.5kg/cm <sup>2</sup>
Belt speed (MAX)		4m/min
Fusing time		6~24s
Working width		450mm
Dimension		L 880 x W 1660 x H 620
Weight		167Kg

## 2 Operating Instructions

### 2.1 Introduction

**Dear customer,**

Thank you for your confidence in our products.

By purchasing this fusing machine TFM 450 you have chosen a unit, which combines excellent quality, simplicity and reliability.

Please carefully study the operating instructions in order to make full use of this machine.

Section 1 describes the product information.

Section 2 describes the operating Instructions.

Section 3 contains a list of important spare parts.

Section 4 contains the electric circuit diagram.

We wish you much success.

## 2.2 Warnings and Safety Instructions

Only use the voltage and type of current shown on the machine plate.

The customer is responsible for the mains supply and ensures the earthing security of the machine.

Take note of the regulations of the local electric suppliers.

Electric faults must only be repaired by qualified personnel.

Disconnect the power supply before opening the machine.

In an emergency, the machine can be stopped by pushing off the stop button (7) (See page 10) or by pulling out the main plug or by operating the main switch (1) (See page 10).

This machine operates at high-temperature; therefore the cover becomes very hot. Danger of burning during operation.

Please don't touch the machine and belt with your hand during operation: Danger of burning and injury from moving parts.

Be careful when you insert material into the machine. Danger of burning and the injury if clothing or body parts are sandwiched between machine parts.

After the operation, please turn off the timer switch. When the surface temperature of the belt is below 90 degrees, the machine stops automatically, and then disconnects the main switch.

Please disconnect the power supply and ensure the machine is in cool condition, then remove the strip-off device for cleaning. Moreover, when you remove the finished material from the exit, pay attention not to be caught in the rotary strip off device.

Clean the belt with a well dried cloth when the operation is over. Please reduce the belt speed for fear of such accidents as burn and material involved.

Please check the belts at the end of every day, to remove all glue from the belts, so as not to damage belts before you begin any maintenance work. You must ensure the electrical supply is off and the machine is cool to prevent accidents and burns.

Please understand all switches of this machine before operating them.

Please keep enough space around the machine for maintenance.

The machine has emergency stop switches when the belt over moves too far to the left or right. Please



COOLSET

Coolset TFM 450  
*Coolset TFM 450 Table Fusing Machine*

take out the material with the manual handle of the attachment if emergency stop or power failure caused machine stop working.

## 2.3 Installation instructions

### 2.3.1 Installation

This machine weighs 167kg. Ensure to install on a robust table and in a level position.

Please install the front table on front table support of the main unit.

### 2.3.2 Electrical connection

Connect the machine to an exclusive power source corresponding with the power consumption by referring to the specifications.

Ensure the machine is correctly grounded according to the electrical requirements of your country. This is a single phase machine so the directing of the belt will always be correct.

## 2.4 Operating

### 2.4.1 Commissioning and Start-up

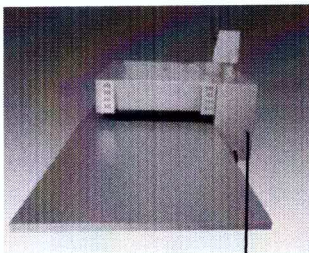

1

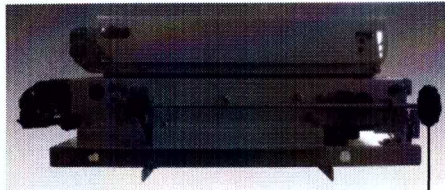

2

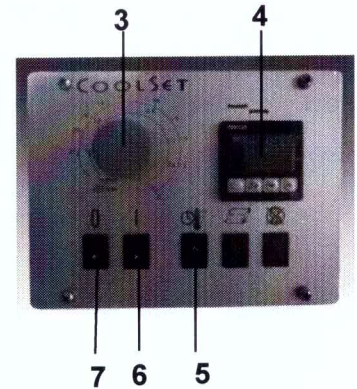

7

6

5

1. Main switch
2. Pressure adjustment handle
3. Knob for potentiometer
4. Temperature thermostat
5. Timer switch
6. Start button
7. Stop button

Set the main switch (1) to the position "ON". (Ensure the timer switch (5) is set to "OFF").

Press the start button (6). (Ensure timer switch (5) has been reset).

Set designated pressure by turning the pressure adjustment handle (2).

Set the fusing time by using the potentiometer knob (3).

Set the setting temperature by using the temperature thermostat (4). After the machine has reached the set temperature, please wait at least 10 minutes longer before starting production. Now you are able to start the fusing operation.

## 2.4.2 The holding's adjustments

In case you want to strengthen the clamping effect of the belts at the entrance of the machine for pocket folding and similar use, turn the adjustment handle (7) to the right to reduce the gap.

The hand wheel 8 is used for adjusting the belt pressure. Refer to the pressure gauge to see pressure in below picture No.9. Pressure increases from -1 to 1.5. Warning: pressure regulating should not exceed 1.5.

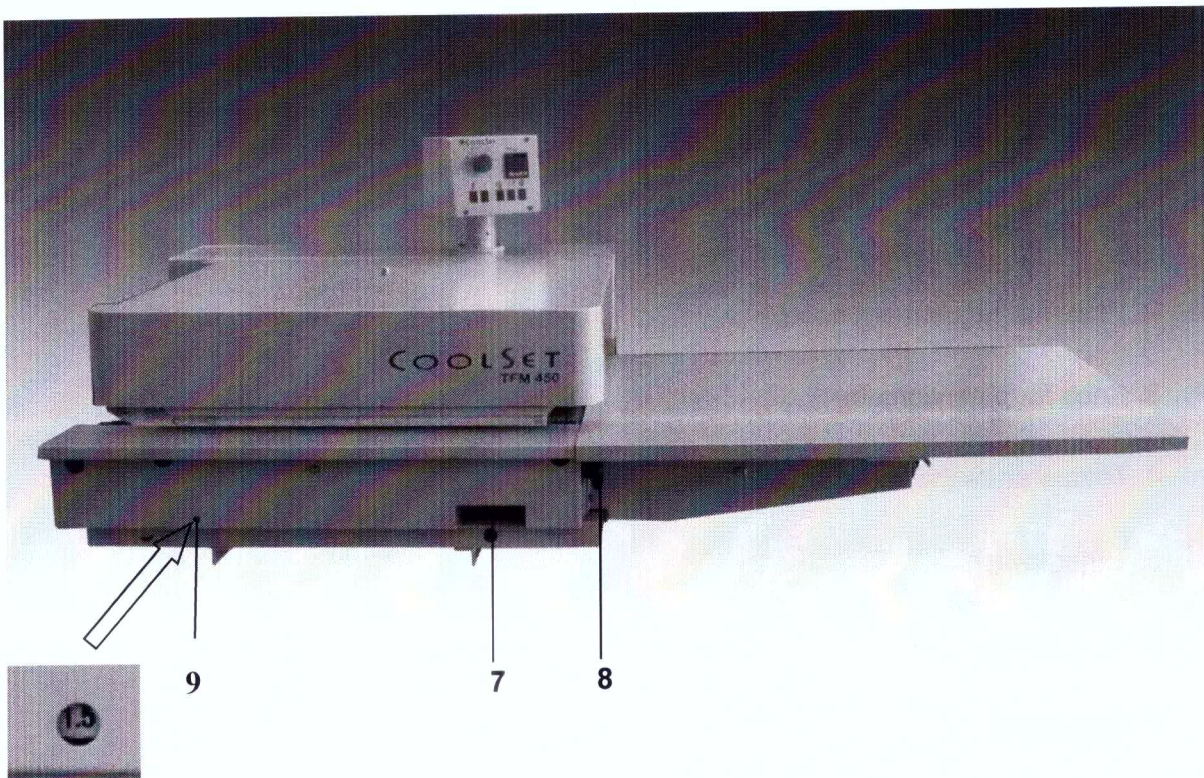

- 7. Belt gap adjustment handle
- 8. Pressure adjustment handle
- 9. Pressure gauge

## 2.4.3 Thermostat setting

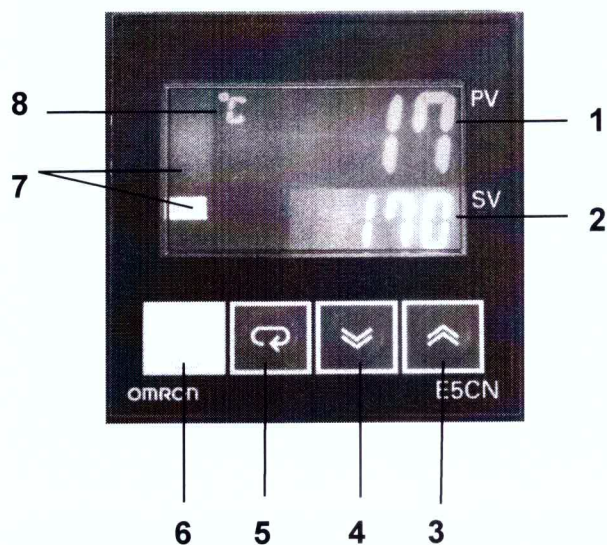

Position	Functions
1	Temperature display ACTUAL VALUE
2	Temperature display SET VALUE
3	Up button for adjustment of set temperature
4	Down button for adjustment of set temperature
5	Button for operating methods (only for skilled personnel)
6	Button for levels (only for skilled personnel)
7	Function indication
	Light " Out 1 " is off (The heating system is switched off)
	Light " Out 1 " is on(The heating system is switched on)
8	Temperature measuring unit in °C (Grad Celsius) or F (Fahrenheit)

### Note:

Please use the up and down buttons (pos. 3 + 4) for the setting of set temperature (pos. 2).

## 2.4.4 Upper belt replacement

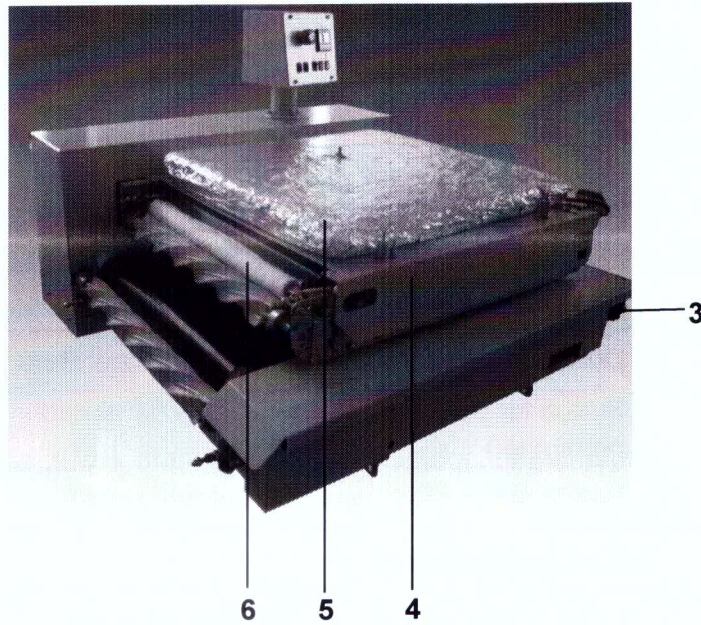
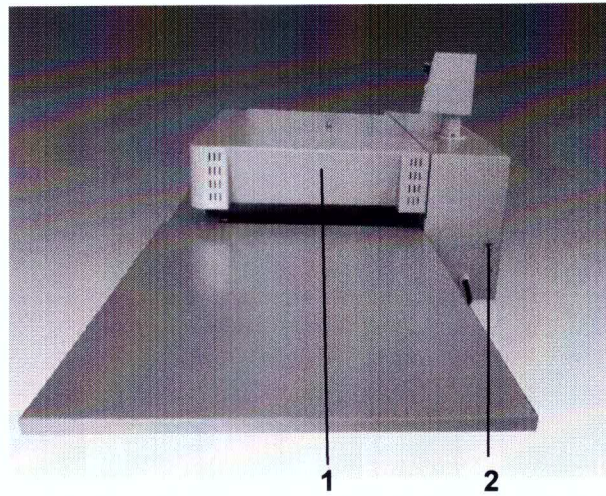

1. External cover
2. Power switch
3. Pressure adjustment handle
4. Cover
5. Heat insulation
6. Wiper bar

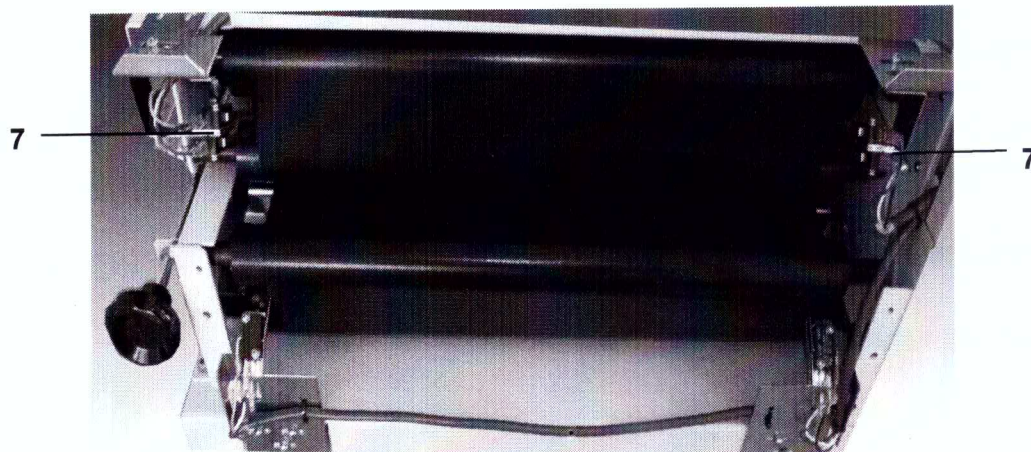

- 7. Belt tracking limit switches
- 8. Tensioning roller
- 9. Tensioning spring
- 10. Rotating strip off device support

***Upper belt replacement***

Switch off main switch (2), disconnect power plug and set the pressure to “-1” by the pressure adjustment handle (3).

Dismantle the external cover (1).

Remove upper belt tracking limit switches (7).

Remove the cover (4) and heat insulation (5).

Remove the wiper bar (6).

Remove the tensioning spring (9) of both sides.

Remove the tensioning roller (8).

Remove the rotary strip-off support (10).

Remove the belt.

Reassemble in the reverse order.



## 2.4.5 Lower belt replacement

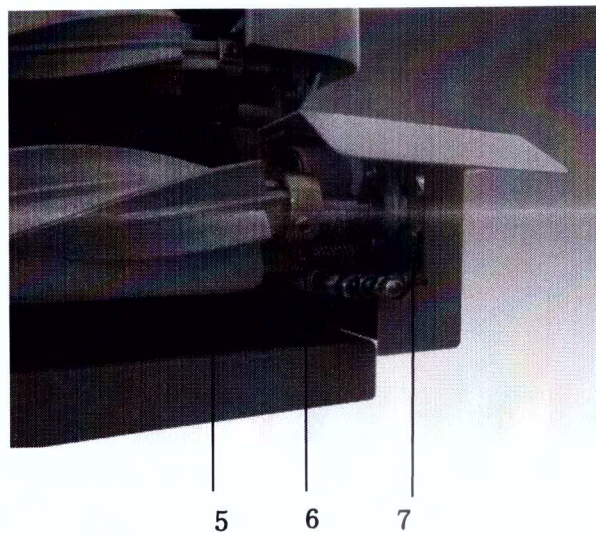
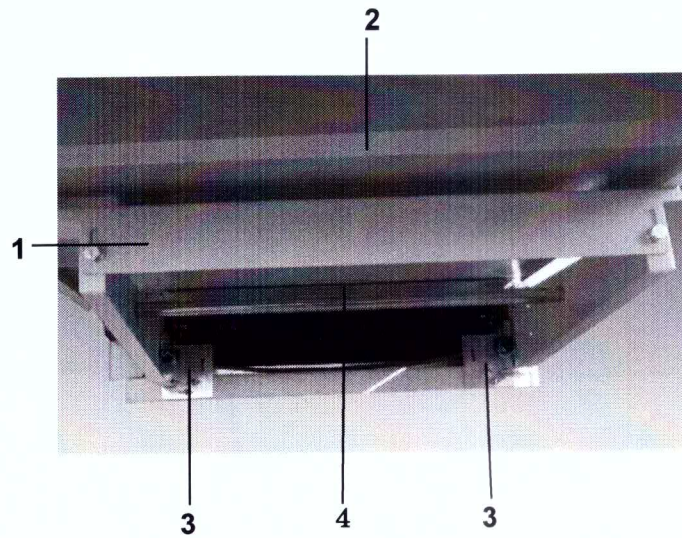

1. Front table support
2. Front table
3. Belt tracking limit switches support
4. Belt protection support
5. Tensioning roller
6. Tensioning springs
7. Rotating strip-off device support

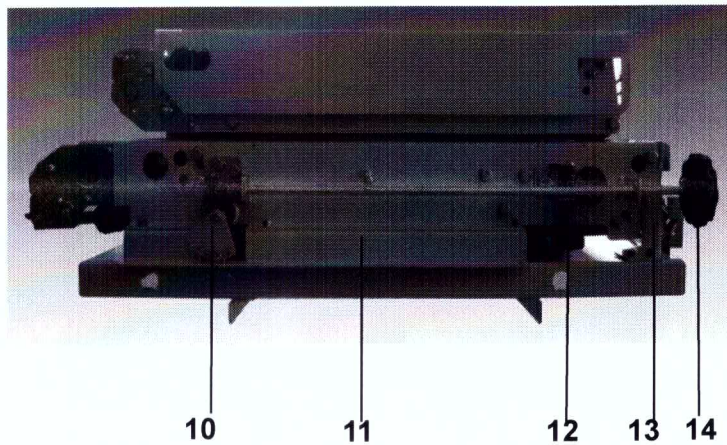
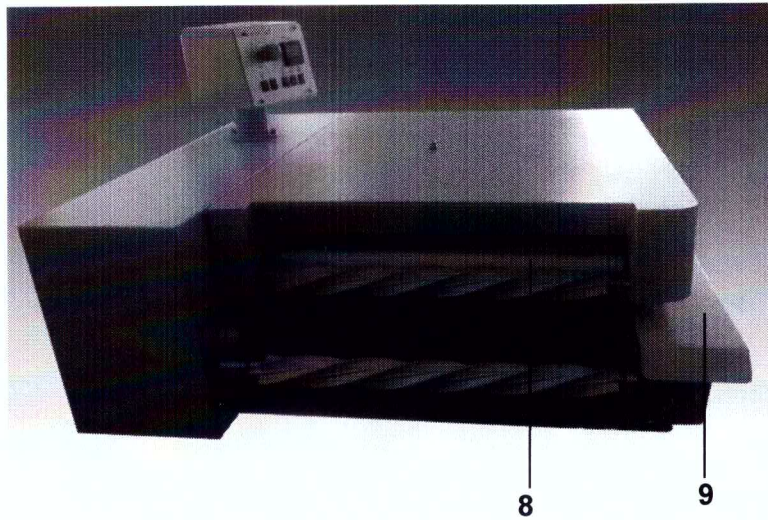

8. Wiper bar

9. Side table

10. Pressure meter

11. Frame spacer

12. Belt gap adjustment handle

13. Left frame support

14. Pressure adjustment handle

## ***Lower belt replacement***

Switch off main switch, disconnect power plug and set the pressure to " -1 " by the pressure adjustment handle (14)

Remove the front table (2).

Remove the front table support (1).

Remove the belt protection support (4).

Remove the side table (8).

Remove the left frame support (13).

Remove the left lower belt tracking limit switches support (3).

Remove the pressure meter (10).

Remove the pressure adjustment handle (14).

Remove the wiper bar (9)

Remove the tensioning springs (6).

Remove the tensioning roller (5).

Remove the rotating strip-off device support (7).

Remove the frame spacer (11).

Remove the belt.

Reassemble in the reverse order.

## 2.4.6 Breaks and Finishing Service

### Breaks

If an emergency stop occurs or put other things to the belt's entrance by mistake, you can stop the machine by main switch and adjust the pressure to 0, then put the T-typed wrench on to the screw for emergency use on the side of the main unit and take out the material.

In the case where a hard object has been put in the machine, ensure complete safety before resuming the operation. Carefully check the teflon belt and rubber parts of the pressure roller for any damage, Replace if necessary.

In the case of an electric failure, adjust the pressure to 0, then put the T-typed wrench on to the screw for emergency use on the side of the main unit and take out the material.

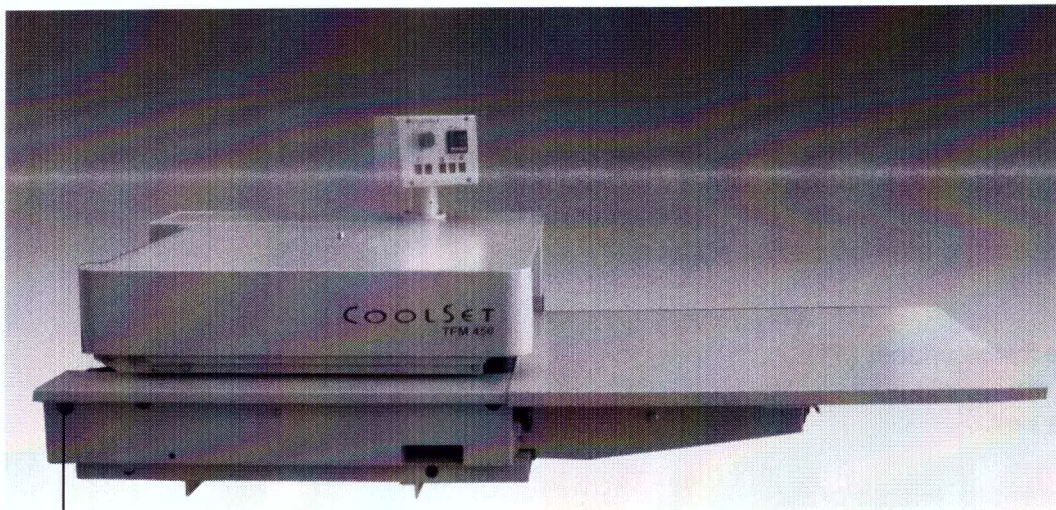

Emergency screw

### **Finishing Operation**

Set the pressure to 0 (zero).

Set the timer switch to 'ON'. The machine stop automatically when the surface temperature of the belt is below 90 degrees.

When the machine has stopped, turn off the power supply.

## **2.5 Maintenance and Service**

The machine must always be cleaned before switching off: Any remaining adhesive hardens overnight and can destroy the belts when the machine is restarted.

We recommend KANFIX non silicon belt cleaner.

Never clean with aggressive materials containing silicon or sharp, hard tools: They shorten the life of the belts and rubber coated rollers.

### **Cleaning the wiper bar**

The wiper bar is installed at the rear of the machine. At the start of the cleaning procedure, pay attention to the cleaning surface and ensure it makes contact with to belt. Check the wiper bar at least twice a day and if necessary change the dirty surface.

## 3 Spare Parts List

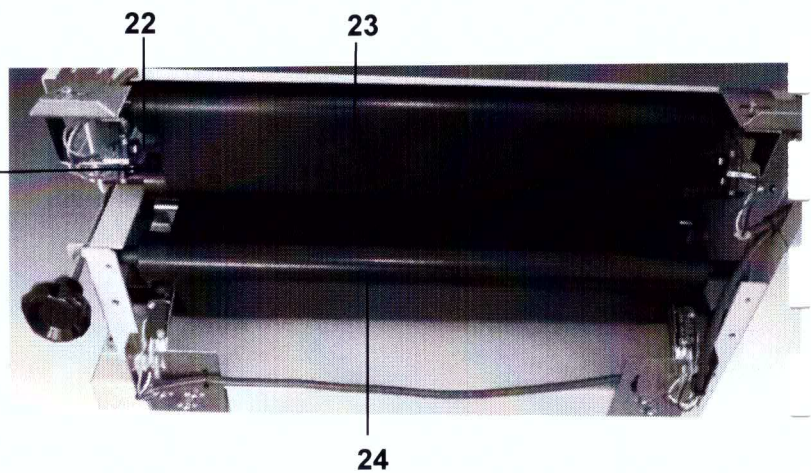
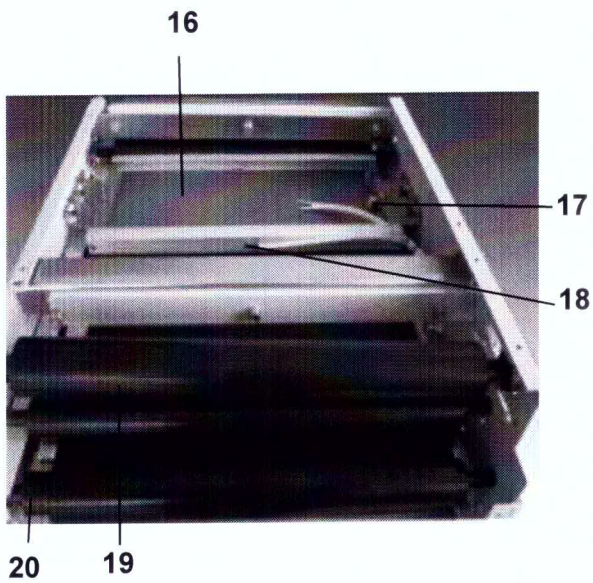
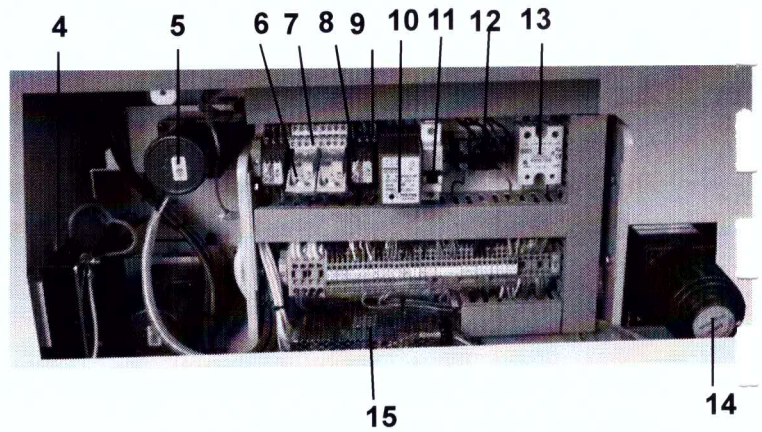
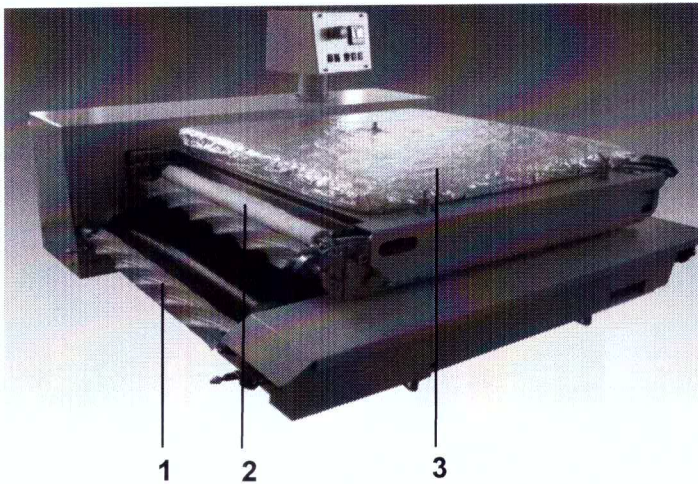

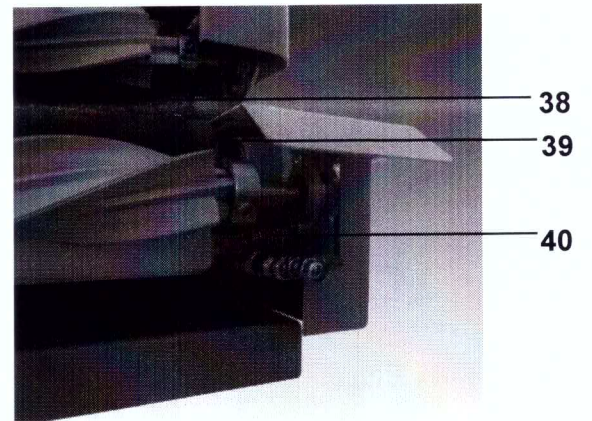
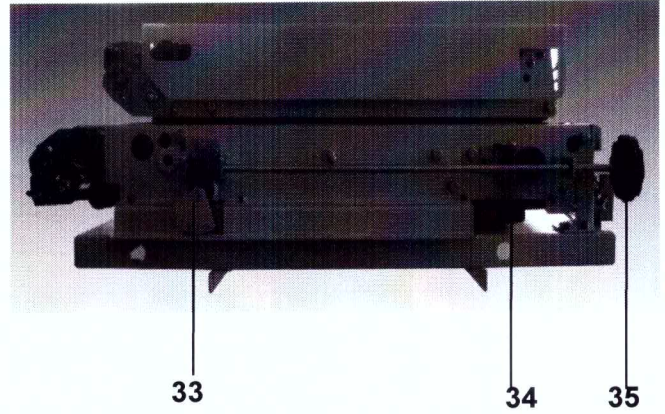
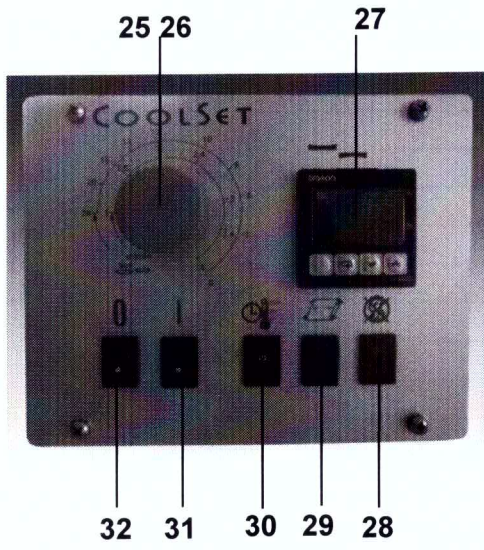

<i>Position</i>	<i>Designation</i>	<i>type</i>	<i>Art.-No.</i>
1	Rotary strip-off device		HJ020077
2	Wiper bar		FL020343
3	Heat insulation		FL030632
4	Power switch		DQ010371
5	Servo motor		DQ010317
6	Relay		DQ010173
7	Relay seat		DQ010174
8	Relay		DQ010177
9	Relay seat		DQ010178
10	Electronic speed regulator		DQ020153
11	Circuit breaker		DQ010015
12	Control relay		DQ020151
13	Solid state relay		DQ010209
14	Geared motor		DQ010316
15	DC 24V power supply		DQ010033
16	Heating element		DQ010354
17	Thermal protector		DQ010355
18	Thermo-couple		DQ010370
19	Correcting roller		HJ020083
20	Supporting roller		HJ020086
21	Belt tracking limit switch (Emergency stop)		DQ010369
22	Belt tracking limit switch		DQ010369
23	Upper Teflon belt		FL030641
24	Lower Teflon belt		FL030642
25	Potentiometer		DQ020320
26	Knob for potentiometer		DQ020300
27	Temperature thermostat		DQ020150
28	Malfunction indicator		DQ020324
29	Transfer belt indicator		DQ020324
30	Timer switch		DQ020323
31	Start botton		DQ020322
32	Emergency switch		DQ020321
33	Pressure meter		BJ090032
34	Belt gap adjustment handle		FL030649
35	Pressure adjustment handle		FL030630
36	Tensioning roller		HJ020085
37	Tensioning spring		FL020341
38	Upper pressure roller		FL030633
39	Lower pressure roller		FL030634
40	Cleaning spring		FL020337
41	KANFIX belt cleaner		JK020213



## 4 Circuit Diagram Electric

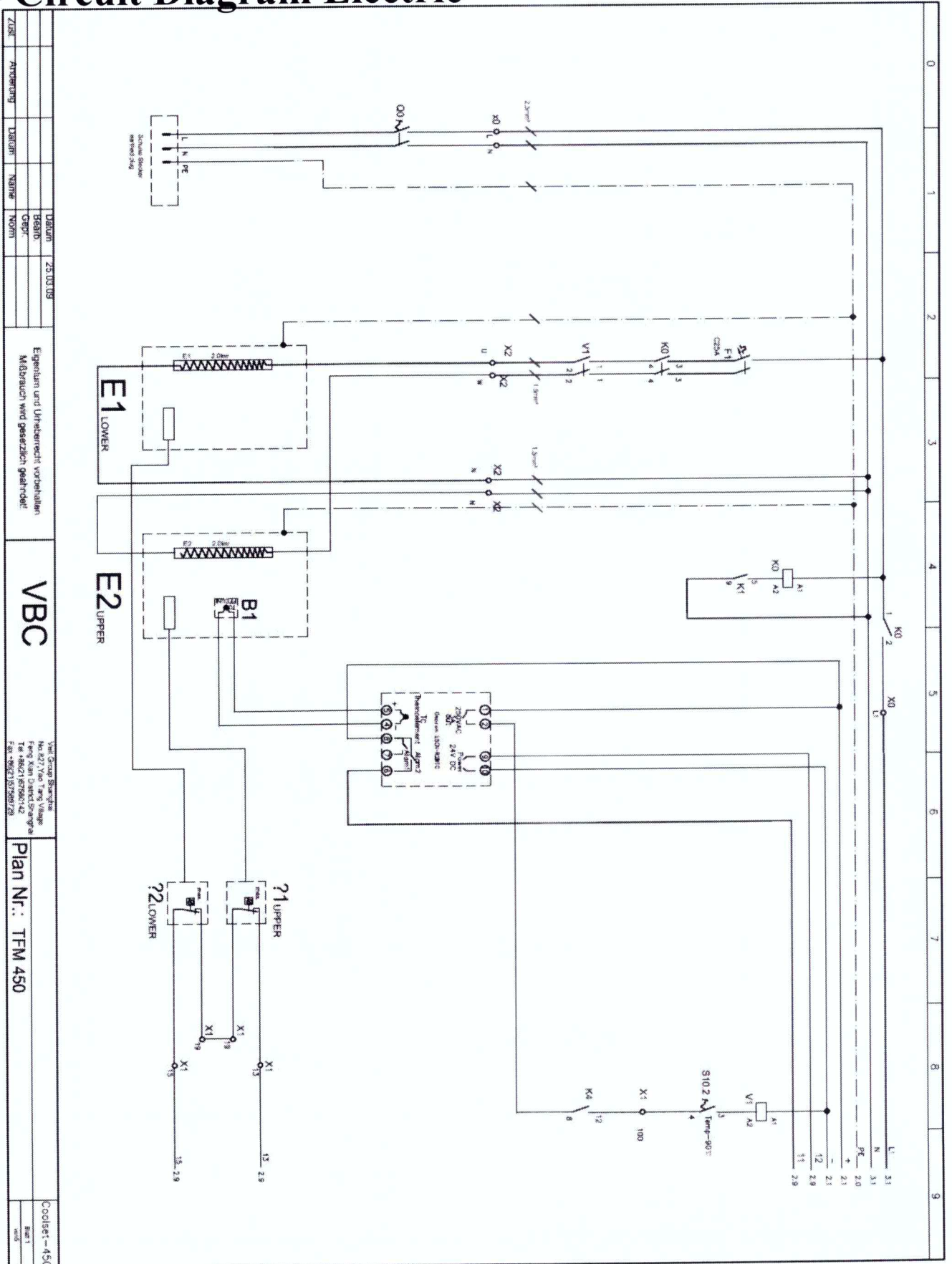

ZUSATZ	Änderung	Datum	Name	Datum	23.10.19	Eigentum und Urheberrecht vorbehalten Mißbrauch wird gesetzlich geahndet!	VBC	Yue Group Shanghai No. 827, Yue Tang Village Fang Xian District, Shanghai Tel: 8621 67506142 Fax: 8621 67506178	Plan Nr.: TFM 450	Coolset-450 Blatt 1 von 1
--------	----------	-------	------	-------	----------	--	-----	---	-------------------	---------------------------------

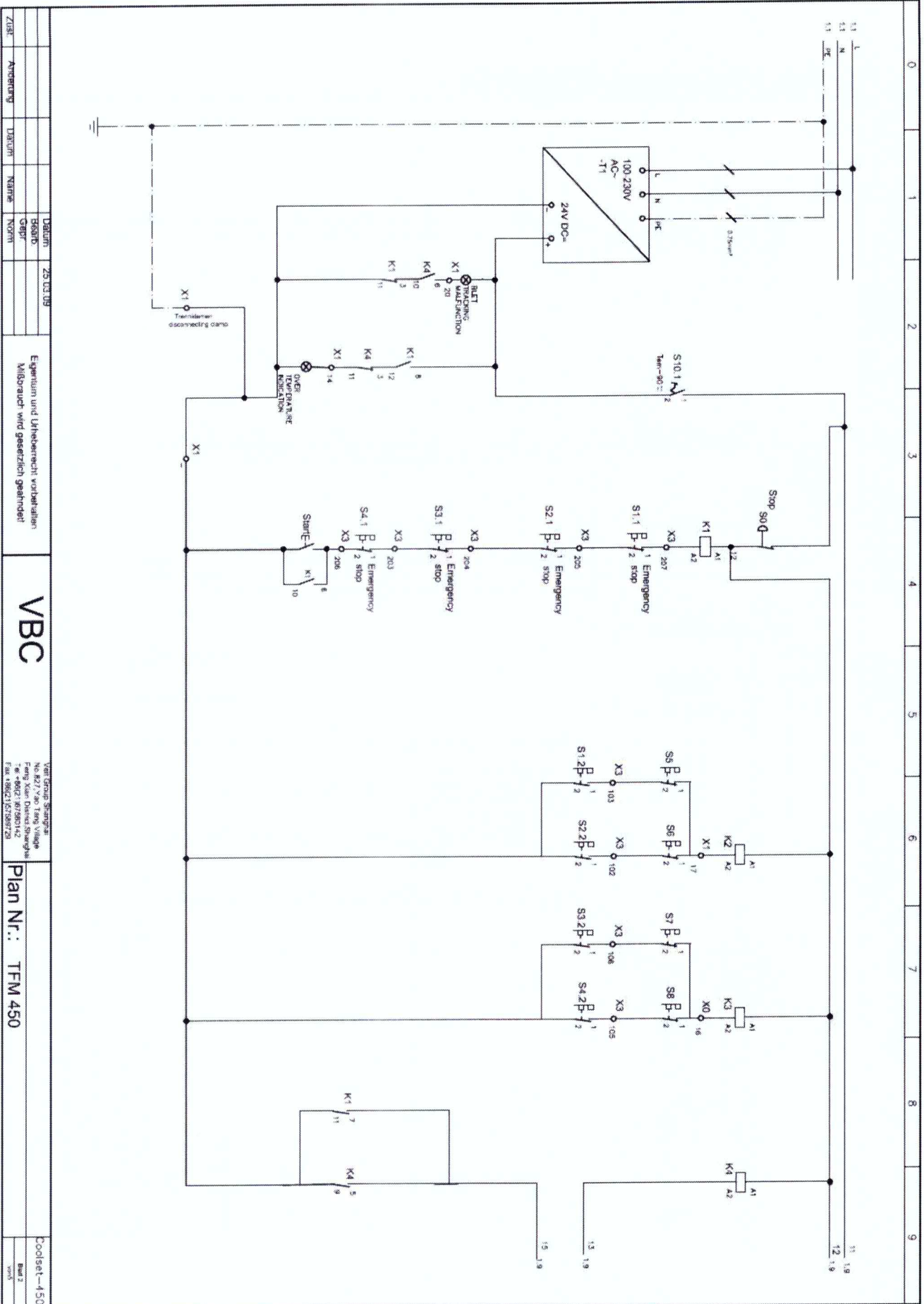

ZUR: Anfertigung	ÜBERN: NAME	ÜBERN: 25.03.09	Eigentum und Urheberrecht vorbehalten Missbrauch wird gesetzlich geahndet!	<b>VBC</b>	Vatongang Sengca No.827 Yao Tong Village Feng Xian Diansi Shuanghai Tel: +8627 87980142 Fax: +8627 515798728	Plan Nr.: TFM 450	Coolset-450 Blatt 2 von 3
------------------	-------------	-----------------	---	------------	--	-------------------	---------------------------------

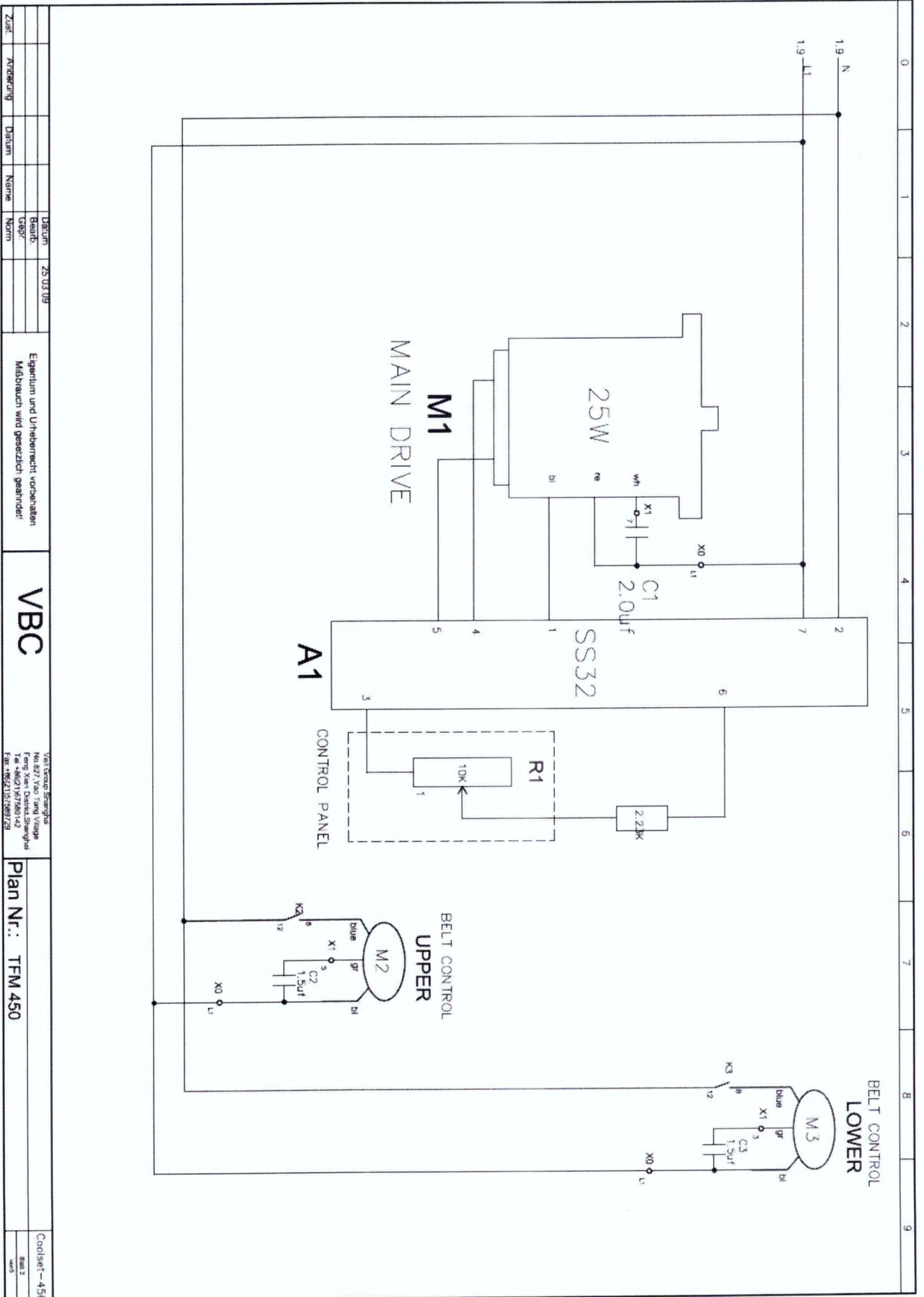

Zust:	Änderung:	Datum:	Name:	Norm:	Datum:	25.03.19:	Handl.:	Capf.:	Edg.:	Edg.:	Eigentum und Urheberrecht vorbehalten	VBC	Von Guang Shenghua No.827 Yao Tang Village Feng Xian District Shanghai Tel: +8621 987880142 Fax: +8621 987880128	Plan Nr.: TFM 450	Coolset-450
-------	-----------	--------	-------	-------	--------	-----------	---------	--------	-------	-------	---------------------------------------	-----	--	-------------------	-------------

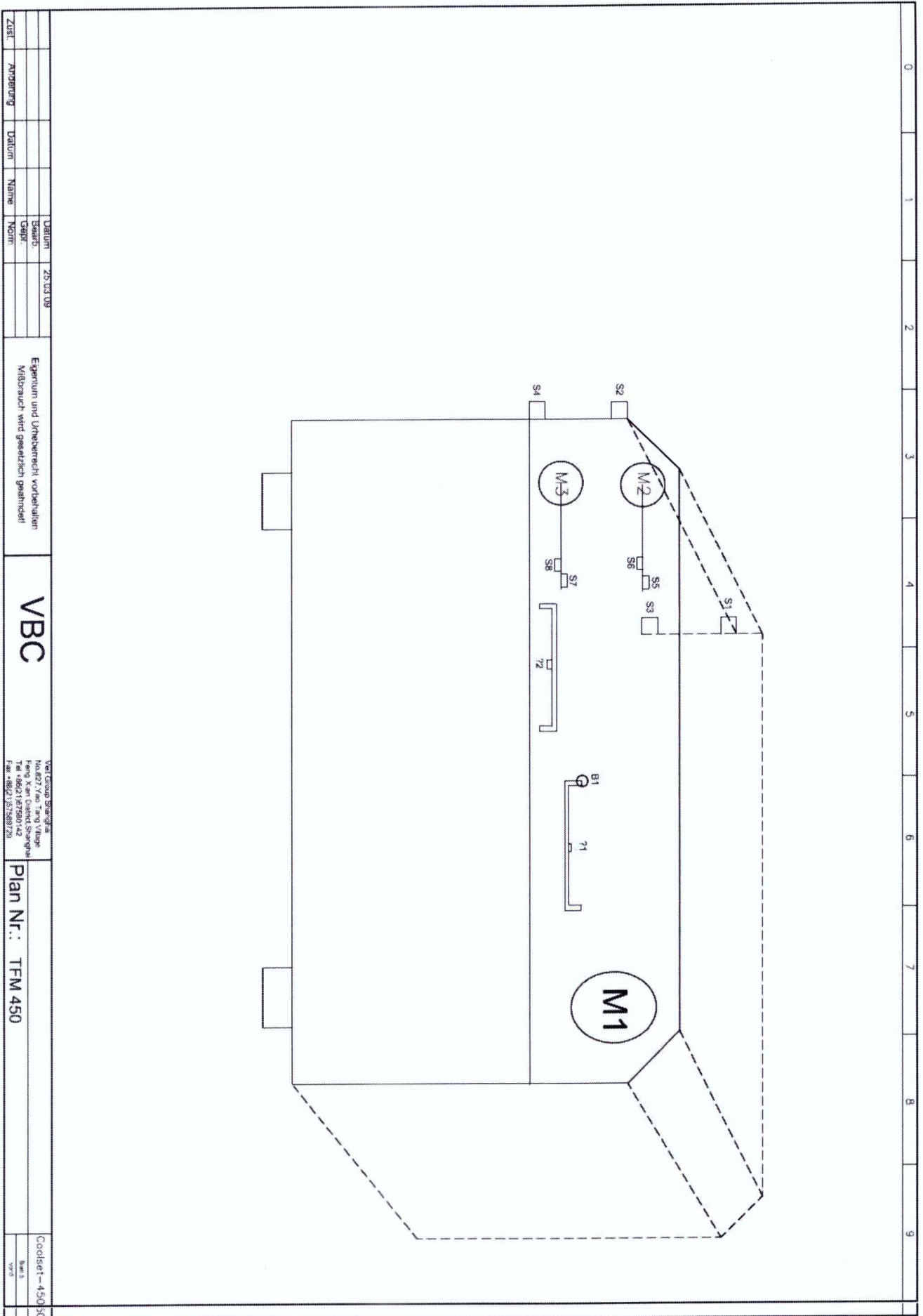

## 7. EC Declaration of Conformity

**EG-Konformitätserklärung / EC declaration of conformity / Déclaration "CE" de conformité  
EF-overensstemmelseserklæring / EG-verklaring van overeenstemming  
Declaración CE de conformidad / Dichiarazione CE di conformità / Declaração CE de  
conformidade**

**VEIT Uniset S / S+B (4235, 4435, 4255, 4455)**      Seriennr. / Serial no: -----

Hiermit erklären wir, dass die Bauart des genannten Geräts in der gelieferten Ausführung folgenden einschlägigen Richtlinien entspricht:

Herewith we declare that the supplied model complies with the following provisions applying to it:

Par la présente, nous déclarons, que le modèle fourni correspond aux dispositions pertinentes suivantes:

Hermed erklæres, at produkttypen er i overensstemmelse med fØlgende bestemmelser:

Hiermede verklaren wij, dat de in de handel gebrachte machine voldoet ann de eisen van de in het vervolg genoemde bepalingen:

Por la presente, declaramos que el modelo suministrado satisface las disposiciones pertinentes siguientes:

Con la presente, si dichiara che il modello fornito è conforme alle seguenti disposizioni pertinenti:

Com a presente, declaramos que o modelo fornecido da está em conformidade com as disposições pertinentes, a saber:

### EG-Richtlinie Maschinen 2006/42/EG

### EMV-Richtlinie 2004/108/EG

Angewandte harmonisierte Normen, insbesondere:

Applied harmonized standards, in particular:

Harmoniserede standarder, der blev anvend, i særdeleshed:

Normes harmonisées utilisées, notamment:

Gebruikte geharmoniseerde normen, in het bijzondere: particularmente:

Normas armonizadas utilizadas,

Norme armonizzate applicate in particolare: particular:

Normas armonizadas utilizadas, em

**DIN EN ISO 12100-1**

**DIN EN ISO 12100-2**

**DIN EN 60204-1**

**DIN EN 61000-6-2**

**DIN EN 61000-6-4**

**DIN EN 55011**

Bevollmächtigter für die Zusammenstellung der technischen Unterlagen:

Authorized representative for the compilation of the technical documents:

Fondé de pouvoir pour l'établissement des documents techniques:

Bemyndiget til sammenstilling af de tekniske dokumenter:

Gemachtigde voor de samenstelling van de technische stukken:

Procurador com poderes para a compilação da documentação técnica:

La persona autorizada para la disposición de los documentos técnicos:

Delegato per la compilazione dei documenti tecnici:

**Firma VEIT GmbH, Justus-von-Liebig-Straße 15, D-86899 Landsberg**

**Veit Group Zhejiang**

**Veit Zhejiang Co, Ltd No.1111 Dongxi Road, Haiyan Country Zhejiang Province China 314304**

Zhejiang, 13 JULY 2012

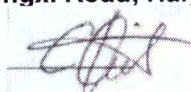

**General manager Christopher Veit**

COOLSET

Coolset TFM 450  
*Coolset TFM 450 Table Fusing Machine*